

1 - BRAKING
2 - RUNNING

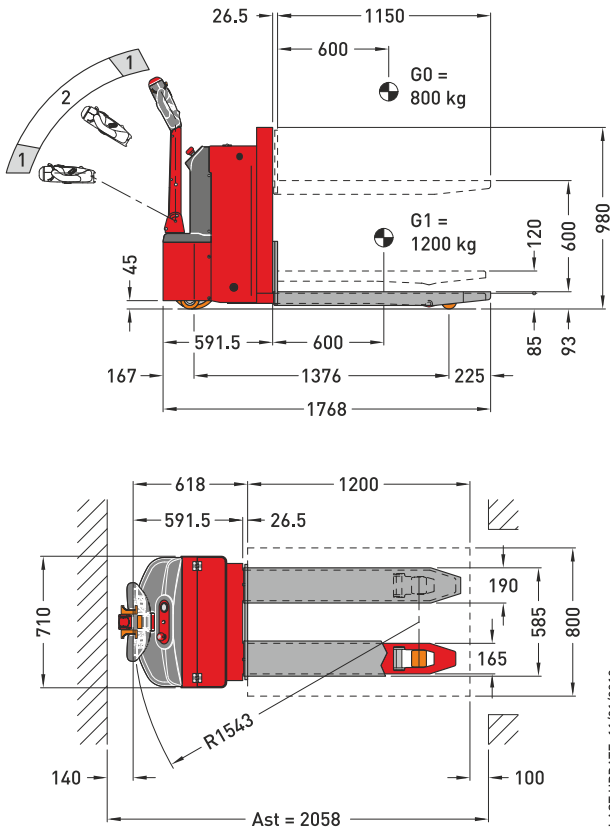

GENERAL SPECIFICATIONS

MODEL	TPL20-DOUBLE LIFT	
Load capacity as pallet truck	2000 kg	
Load capacity of the lifting mast	G0 = 800 kg	
Combined load capacity front legs + lifting mast	G1 = 1200 kg + G0 = 800 kg	
Front height from the ground	lowering front legs: 85 mm lowering lifting legs: 93 mm	
Weight with acid/lead battery 24V 200Ah	555 kg	
Track of front rollers	485	
Track of rear stabilizer wheels	554	
Height of tiller head (brake releasing)	min	790
	max	1080
Size of single front rollers standard - polyurethane	n° 2 rollers ø 80 × 90	
Size of double front rollers optional - polyurethane	n° 2+2 rollers ø 80 × 70	
Size of traction wheel	polyurethane	ø 250×79
Size of rear stabilizer wheels	polyurethane	ø 100 × 40
Travel speed	with load	4,8 km/h
	without load	5,5 km/h
Lifting speed	with load	0,072 m/s
	without load	0,110 m/s
Lowering speed	with load	0,380 m/s
	without load	0,110 m/s
Max gradeability	with load	6,0%
	without load	17,0%
Brake	Electromagnetic	
Electronic control type	MOSFET 24V 200A	
Traction motor power	series excite system	1200 W
Pump motor power	800W	
Noisiness	65 dB	
Battery box size (L × W × H)	151 × 635 × 660	

BATTERIES

Acid/lead traction battery 24V - 200Ah/5h 160 kg

WEIGHT

TECHNICAL FEATURES

Pallet truck pedestrian controlled.
Load capacity 2,000 kg
Mast forks load capacity up to 800 kg and lifting height of 693 mm.
Truck forks load capacity up to 2000 kg and lifting height of 205 mm.
Combined load capacity up to 800 kg on the mast forks + 1200 kg on the truck forks.
MOSFET electronic controller up to 24V 200A.
Hydraulic unit up to 24V 800W with electric descending valve.
24Vof200W drive motor with series excite system complete electromagnetic brake.
Battery charger indicator.
Single front rollers.
Switch to operate with the tiller in the upright position.
Forks length 1150 mm both for mast and truck.
Mast forks track 585 mm
Truck forks track 560 mm.
Packing on wooden pallet included in the price.

OPTIONAL

Heavy Duty pack: metal rear cover
Heavy Duty pack: drive wheel ring in VULKOLLAN®
Forks track 660 mm and forks length 1.150 mm
Battery charge indicator with LCD hours counter and block of the forks with flat battery
Double front rollers
Lateral pallet entry and exit rollers
Load holder grate (dimensions 730 × 630 mm)
Drive wheel ring in trail-proof soft polyurethane with carved tread
Cold store version at -30°C
Automatic topping up for batterie complete of tank and connectors