

1 - BRAKING
2 - RUNNING

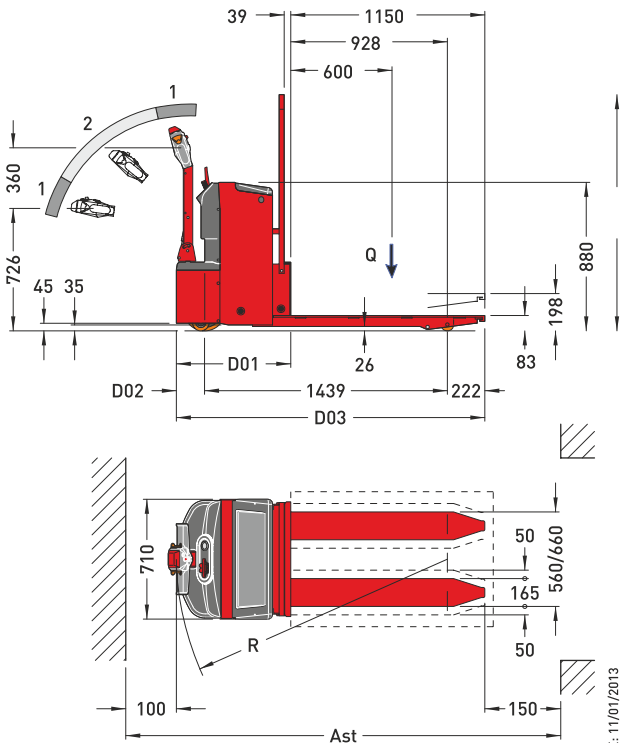

LAST UPDATE: 11/01/2013

NOTE: the width of the forks of 660 mm is an optional

BATTERIES

		WEIGHT
Traction battery	24V - 180Ah/5h	175 kg
Traction battery	24V - 230Ah/5h	228 kg

TECHNICAL FEATURES

- Pallet truck pedestrian controlled.
- Single front rollers.
- Switch to operate with the tiller in the upright position.
- Fork side shift 50 mm right + 50 mm left complete of load holder grate.
- MOSFET electronic controller up to 24V 200A.
- Forks length 1.150 mm and section 165x70 mm.
- 24V 800W (TPL16-T) / 24V 1200W (TPL20-T) drive motor with series excite system complete of electromagnetic brake.
- Battery charge indicator with LCD hours counter and block of the forks with flat battery.
- Hydraulic unit up to 24V 800W with electric descending valve.
- Forks track 560 mm.
- Forks lifting height of 115 mm.
- Packing on wooden pallet included in the price

GENERAL SPECIFICATIONS

MODEL		TPL16-T	TPL20-T
Length without forks	D01	678	678
Rear distance between axles	D02	167	167
Total length	D03	1828	1828
Working isle width	Ast	2078	2078
Steering radius	R	1606	1606
Load capacity		1600 kg	2000 kg
Weight (without battery)		285 kg	310 kg
Front track		485 / 585	
Rear track		554	
Height of tiller in gear position (brake releasing)	min	790	
	max	1080	
Double front rollers size	standard - polyurethane	n° 2+2 rollers ø 70 x 70	
Drive wheel size	polyurethane	ø 220x70	ø 250x79
Additional wheels size	polyurethane	ø 100 x 40	
Travel speed	with load	4,8 km/h	5,0 km/h
	without load	5,5 km/h	6,0 km/h
Lifting speed	with load	0,014 m/s	0,014 m/s
	without load	0,023 m/s	0,023 m/s
Lowering speed	with load	0,045 m/s	0,045 m/s
	without load	0,044 m/s	0,044 m/s
Max gradeability	with load	6,0%	7,0%
	without load	17,0%	17,5%
Brake		Electromagnetic	
Electronic control type		Mosfet 24V 200A	
Traction motor power	Series Excite System	800 W	1200 W
Pump motor power		800W	
Noise		65 dB	
Battery box size (L x W x H)		215 x 635 x 660	

OPTIONAL

- Forks track 660 mm and forks length 1.150 mm
- Forks track 660 mm and forks length 980 mm
- Drive wheel ring in trail-proof soft polyurethane with carved tread
- Cold store version at -30°C
- Automatic topping up for batterie complete of tank and connectors