

1 - BRAKING  
2 - RUNNING

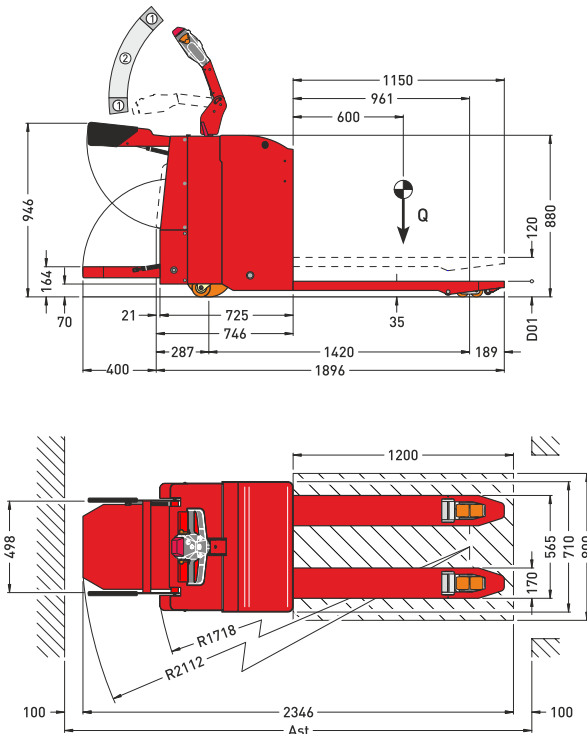

LAST UPDATE: 22/07/2011

## GENERAL SPECIFICATIONS

MODEL		TOPP22	TOPP30
Load capacity	Q	2200 kg	3000 kg
Weight (without battery)		421 kg	448 kg
Track width - front		465	
Track width - rear		538	
Height of tiller arm in working position (brake releasing)	min max	1082 1335	
Height from ground of the lowered forks	D01	85	90
Aisle width (with platform and side arms retracted)		Ast = 2146	
Aisle width (with platform and side arms deployed)		Ast = 2546	
Single front rollers size	polyurethane	ø 80 × 90	not available
Double front rollers size	polyurethane	ø 80 × 70	ø 85 × 70
Traction wheel size	polyurethane	ø 230 × 75	ø 253 × 100
Additional wheels size	polyurethane	ø 100 × 40	
Service brake		Electromagnetic	
Electronic control type		Mosfet 24V 350A	
Drive motor rating	Potenza S2 60 min.	2000 W	2600 W
Lifting motor rating	Potenza S3 15%	2000 W	
Travel speed	with load without load	8,0 (6,0) <sup>1</sup> km/h 10,0 (6,0) <sup>1</sup> km/h	
Lifting speed	with load without load	0,0240 m/s 0,0370 m/s	
Lowering speed	with load without load	0,0315 m/s 0,0340 m/s	
Max gradeability (5 min.)	with load without load	10,0% 20,0%	
Battery compartment size (L × W × H)		292 × 650 × 640	

## BATTERIES

		WEIGHT
Acid/lead traction battery	24V 315 Ah/5h	260 kg
Acid/lead traction battery	24V 345 Ah/5h	275 kg
Acid/lead traction battery	24V 375 Ah/5h	290 kg
GEL traction battery	24V 285 Ah/5h	260 kg
GEL traction battery	24V 330 Ah/5h	299 kg

## WEIGHT

## TECHNICAL FEATURES

Pallet truck with user's platform and side arms.  
MOSFET electronic controller up to 24V 350A.  
Automatic speed reduction on cornering.  
TOPP22: 24V 2000W drive motor with separate excite system complete of electromagnetic brake.  
TOPP22: single front rollers.  
TOPP22: single front rollers.  
TOPP30: 24V 2600W drive motor with separate excite system complete of electromagnetic brake.  
Max travel speed of 10 km/h.  
Hydraulic unit up to 24V 2000W with electric descending valve.  
TOPP30: double front rollers.  
Battery charge indicator with LCD hours counter and block of the forks with flat battery.  
Ip56 tiller head with double buttons to action forks lifting and lowering with left and right hand.  
Switch to operate with the tiller in the upright position.  
Forks length 1.150 mm.  
Forks track 565 mm.  
Forks lifting height of 120 mm.  
Suitable for cold store at -30°C.  
Packing on wooden pallet included in the price.

## OPTIONAL

Standard forks track mm 565 and special forks length mm 2.350 suitable to transport 2 pallets or 3 pallets in a crossway:  
- Additional price for TOPP22  
- Additional price for TOPP30  
Heavy Duty pack: drive wheel ring in VULKOLLAN®  
Special forks track 665 mm and special forks length 980 mm  
Double front rollers (only for TOPP22)  
Lateral pallet entry and exit rollers  
Load holder grate (dimensions 730 × 360 mm)  
Drive wheel ring in trail-proof soft polyurethane with carved tread  
Quick battery change with lateral door and rollers inside the battery box  
Battery cable complete of SB175 connector (for second battery)  
Rollers device with two battery spaces for quick battery change  
Automatic topping up for batterie complete of tank and connectors